

Storers

AIRWING



BRITISH
DESIGNED &
MANUFACTURED



Airwing Multidecks

User Manual



Contents

INFORMATION, SAFETY AND MAINTENANCE	3
INSTALLATION OF AIRWINGS	4
AIRWING DIMENSIONS & INFORMATION	5
AIRWING TEMPERATURE SETTINGS	6
ANCILLARY OPERATING GUIDENCE	7
FOOD STORAGE TEMPERATURE	7
CONTROL DISPLAY – COMMON FAULT CODES	8
MODEL INFORMATION	8

INFORMATION, SAFETY AND MAINTENANCE

- Ensure all grills and ventilation vents are not blocked.
- Ensure no flammable products are stored in the unit.
- Ensure that the digital control display is not tampered with as the unit is delivered pre-set.
- When cleaning the unit do not use industrial cleaners such as pressure washers, steamers, or flood with water.
- Use a soft brush to clean around vents to maintain clear ventilation*.
- Ensure precautions are considered when loading the unit to ensure no damage occurs to the mechanical parts within the unit.
- Always check the power supply cable for damage, if any found please replace immediately ensuring a qualified person is arranged to do so.
- Do not use any other electrical equipment inside the unit.
- Always ensure the unit is moved by 2 persons to avoid injury, do not move over uneven ground.
- When plugging in the unit always ensure the electrical supply is protected with an RCD.
- If the unit requires the fuse to be replaced ensure this is replaced with a 13amp fuse.



When disposing of the unit at the end of life please be aware that some parts and materials are harmful to the environment and will require being disposed of in the correct manner. Always use a recognised, licensed, and professional waste contractor.

*To clean the condenser, use a brush attachment on a vacuum cleaner or small handheld brush. Care must be taken not to damage the condenser. The debris needs to be removed gently, do not use force or stabbing motions with the brush. Cleaning should be completed every 3- 6 months failure to do so may void your warranty and damage to your unit.

INSTALLATION OF AIRWINGS

- Install unit on a flat, clean level and sturdy surface and leave to stand for 60 minutes.
- Always ensure the unit is located away from hot and cold air sources as this will cause temperature issues (i.e. fan heater or air conditioning).
- Do not install the unit where air can be blown directly into the face of the unit.
- Always ensure the unit is connected to a suitable power supply.
- Ensure the unit has adequate ventilation and that no other appliances are blocking the ventilation outlets at either front or rear.
- Do not store items in front of the vents as this will cause temperature issues.
- The unit is delivered pre-set between +3°C and +5°C no alterations of the settings are required.
- Once the unit has gained optimum temperature always ensure that grills are not blocked with overstocking and allow air flow to move around your stock
- Please do not remove ticket strips/air deflectors as this will have a detrimental impact on functionality.
- Air deflectors must be in the downward position, refer to Fig1 below.

Air Deflector, Section View – FIG 1

1

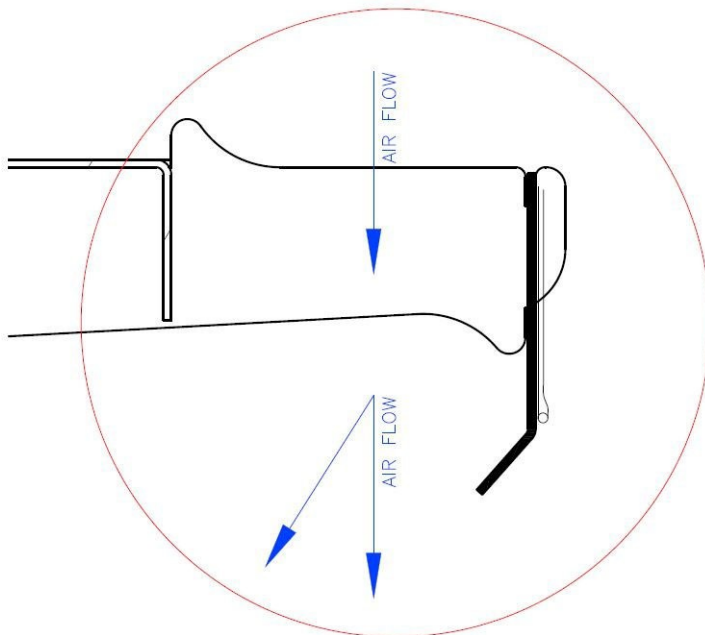

AIRWING DIMENSIONS & INFORMATION

Product Code	Unit Dimensions	Unit Power	Unit Weight
MD700	750x670x1950mm	13amp – 230V ~50H	150kg
MD900	950x670x1950mm	13amp – 230V ~50H	175kg
MD1200	1250x670x1950mm	13amp – 230V ~50H	215kg
MD1500	1550x670x1950mm	13amp – 230V ~50H	265kg
MD1800	1850x670x1950mm	13amp – 230V ~50H	305kg

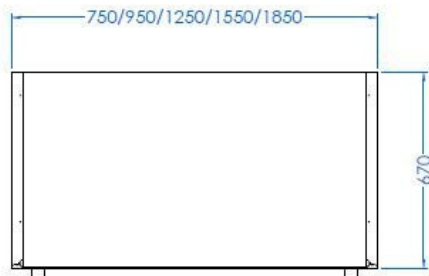

PLAN VIEW

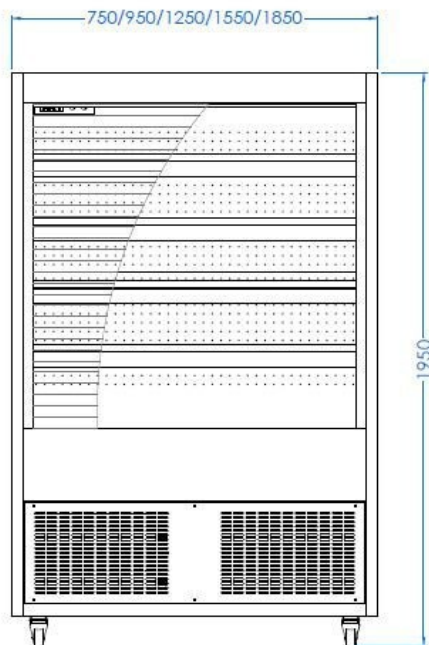

FRONT ELEVATION

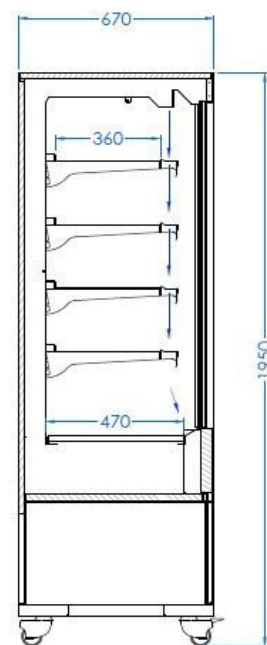

SECTION VIEW

AIRWING TEMPERATURE SETTINGS

Temperature Adjustment & Controller button functions

During normal operation **press and hold** button 1, this will display the current set temperature.

To adjust the set temperature, continue to hold button 1, then either:-

1. Press and release button 2 to lower the temperature incrementally; Or
2. Press and release button 3 to raise the temperature incrementally.

To store the desired temperature release button 1. See fig 2 for button locations.

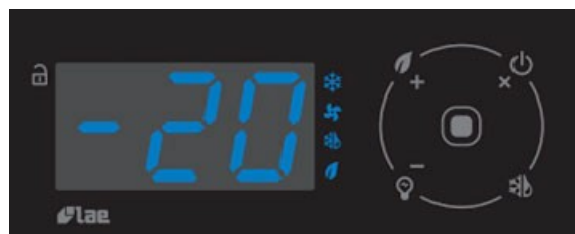
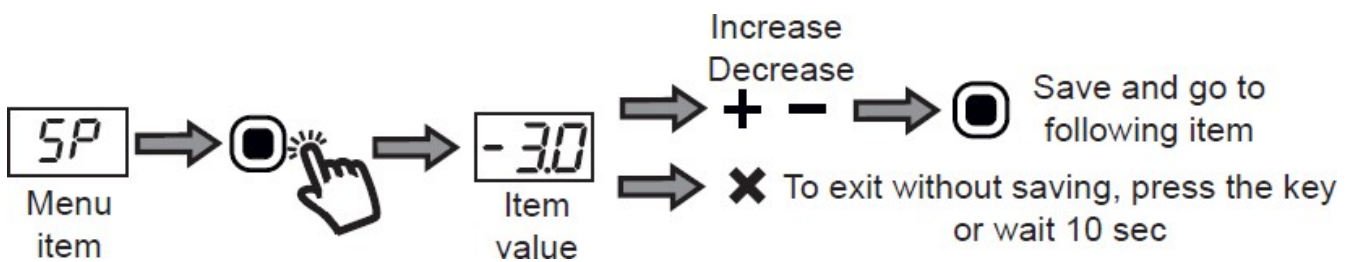

Ancillary Operating Guidance

LIGHT FUNCTION- To switch the light on and off press the m button (button 3)

DEFROST MODE- This cycle will take place periodically throughout the day, it will display as def this is completely normal the user is not required to alter this at any point.

SHUTTERS- All shutters are lockable 2 keys are provided with the unit.

NIGHTBLIND- Simply pull down and secure, this is strongly advised when the unit is not in use to conserve energy and gain temperature stability.

Food Storage temperature

Cold food must be kept at 5 °C or below.

Best practice is to keep your chiller below 5 °C, to make sure that food is kept cold enough.

You should check regularly that your fridge and any other display units are cold enough to ensure food waste is kept to a minimum.

Control Display – Common Fault Codes

DEF	Defrost cycle in progress – No action required.
HI	The internal temperature has risen above the set temperature within the controller. Ensure all grills and ventilation are not obstructed – please pull down the unit shutter or night blind for 1 hour. If the unit still reads HI after this, please call for service.
LO	The internal temperature has dropped below the set temperature. If this persists, please call for service.
E1	Failure has occurred on the air probe. Please remove stock and switch off the unit as set temperatures cannot be maintained, failure to do so may damage the unit. Please call for service.
E2	Failure has occurred to the evaporator probe – Please call for service.

Repairs and Servicing

- All Airwings come with a 2 year warranty which includes parts and labour*
- If you require additional copies of this user manual, please visit the download page of our website at www.storersltd.com
- For in warranty repairs, please call 0115 9200329
- If spare parts are required once the unit is out of warranty, please call: 01159 200329**

*Call outs may be deemed chargeable if down to user error and/or lack of maintenance.

** We endeavour to supply spare parts for the life of the product subject to supplier product availability.

Model Information

To access relevant data in relation to this units energy rating, usage etc as set out in delegated regulation (EU) 2019/2018. A weblink can be followed via scanning the QR code directly on the data plate displayed on the rear of each unit.

All information is stored directly on the EPRAL portal.